



JURBY WATERTECH INTERNATIONAL





Mission - Jurby WaterTech International implements innovative and effective water treatment technologies for all spheres of human life.

Actively developing, technologically integrated engineering and chemical company. The international leader in industrial and drinking water treatment field.





JURBY WATERTECH INTERNATIONAL GEOGRAPHY OF PROJECTS

Countries we work with:

Kazakhstan,
Uzbekistan, USA,
Lithuania, Latvia,
Estonia, Ukraine, Great
Britain, Saudi Arabia,
Egypt, Vietnam,
Bahrain, Kyrgyzstan,
Myanmar, and Romania.





INDUSTRIES WE WORK

OIL REFINING AND
PETROCHEMICAL



OIL AND GAS INDUSTRY



MUNICIPAL UTILITIES SECTOR



AGROCHEMISTRY AND
FERTILIZER INDUSTRY



METALLURGICAL INDUSTRY



AGRO-INDUSTRY



CHEMICAL INDUSTRY



POWER ENGINEERING
INDUSTRY



COAL AND MINING



PHARMACEUTICAL INDUSTRY



FOOD INDUSTRY





OPPORTUNITIES AND BENEFITS OF PRODUCTION CAPACITIES



- American Association of Technical Engineers Certificate of Recognition and Approval ASME S, ASME U, ASME U2.
- Certificate "American Petroleum Institute" on the recognition of conformity with the API Q1 specification.
- Certificate from the "National Board Of Boiler And Pressure Vessel Inspectors" granting the right to use the symbol R.
- Certificate ISO 9001-2016 (9001:2015)

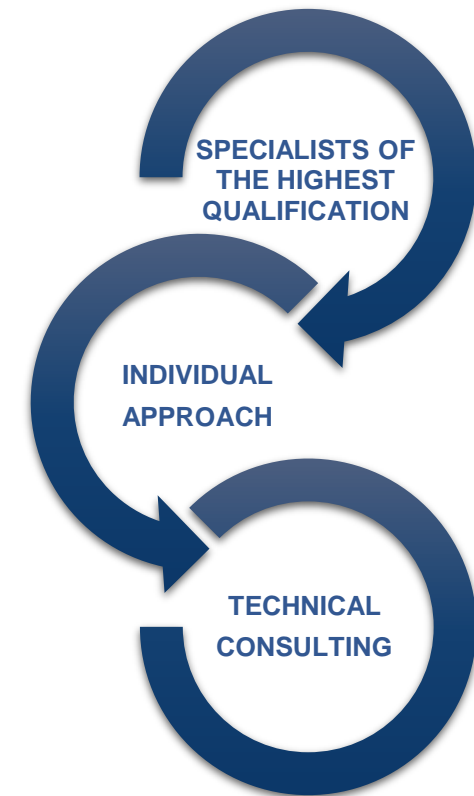



JURBY WATERTECH INTERNATIONAL PRODUCTION FACILITIES

INTERNATIONAL QUALITY STANDARDS

The production base of the company, with an area of 5500 m², is equipped with modern equipment, machine tools, fixtures and tools from leading world manufacturers.

All production processes are certified in accordance with ISO 9001 as well as international standards ASME and EN.

Much attention is paid to modern and efficient methods of organizing, maintaining and managing production processes.



WELDING WORKSHOP



ASSEMBLY WORKSHOP



LONG-TERM WAREHOUSE



LOGISTICS CENTER





JURBY WATERTECH INTERNATIONAL SUPPLIERS:

The company cooperates with world-renowned key suppliers and has agreements that guarantee the uninterrupted supply of components and materials for equipment manufacturing projects.

Jurby Watertech customers are freed from the difficult choice of suppliers and coordination of individual parts of the project, we optimize the financial costs of the client and reduce the likelihood of errors.





JURBY WATERTECH INTERNATIONAL

**ENGINEERING
AND OEM
DIVISION**

**CHEMICAL
WATER
TREATMENT
DIVISION**



JURBY WATERTECH INTERNATIONAL ENGINEERING DIVISION

ENGINEERING AND OEM DIVISION



ENGINEERING DIVISION PROVIDED SERVICES

Technological solutions for water and wastewater treatment, high-quality “Turnkey” project implementation, and service maintenance of industrial and drinking water purification and treatment equipment.

- “Turnkey” project implementation;
- Inspection and analysis of the water treatment systems’ effectiveness;
- Development of optimal engineering solutions;
- Pilot tests;
- Feasibility studies;
- Equipment manufacturing;
- Installation supervision;
- Commissioning;
- Training of operating personnel;
- Service;
- Project management;
- Warranty service.

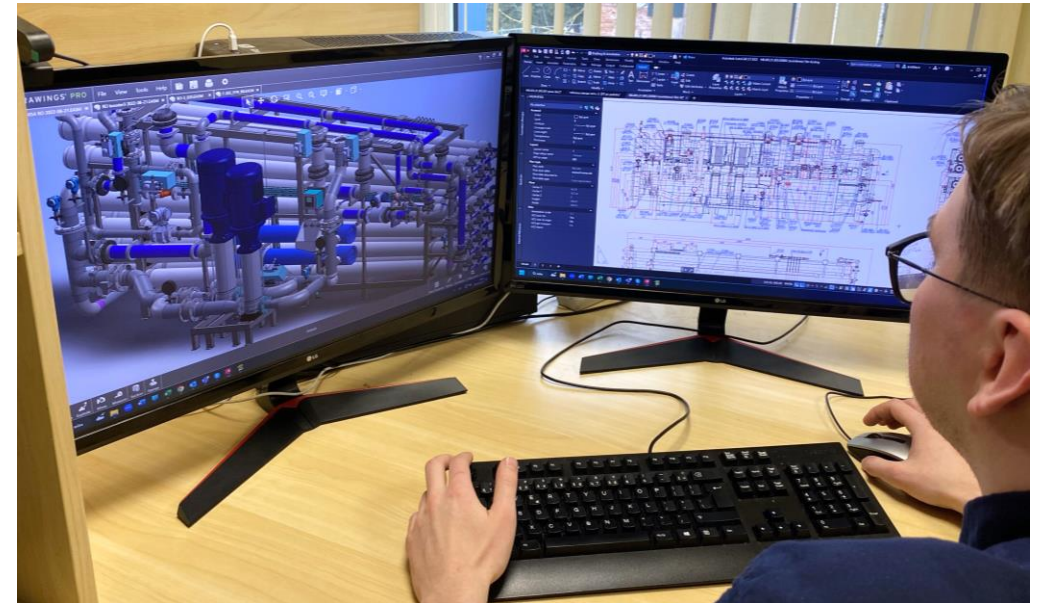



JURBY WATERTECH INTERNATIONAL TAILOR-MADE OEM SOLUTIONS

DESIGNING

We provide basic and detailed design, 3D modeling including final design, specifications, water treatment process technology selection, equipment sizing, and electrical and automation design.

Engineers rely on advanced technology to meet customer requirements and provide high quality water treatment systems. Each application is considered individually, taking into count all the features of the project.

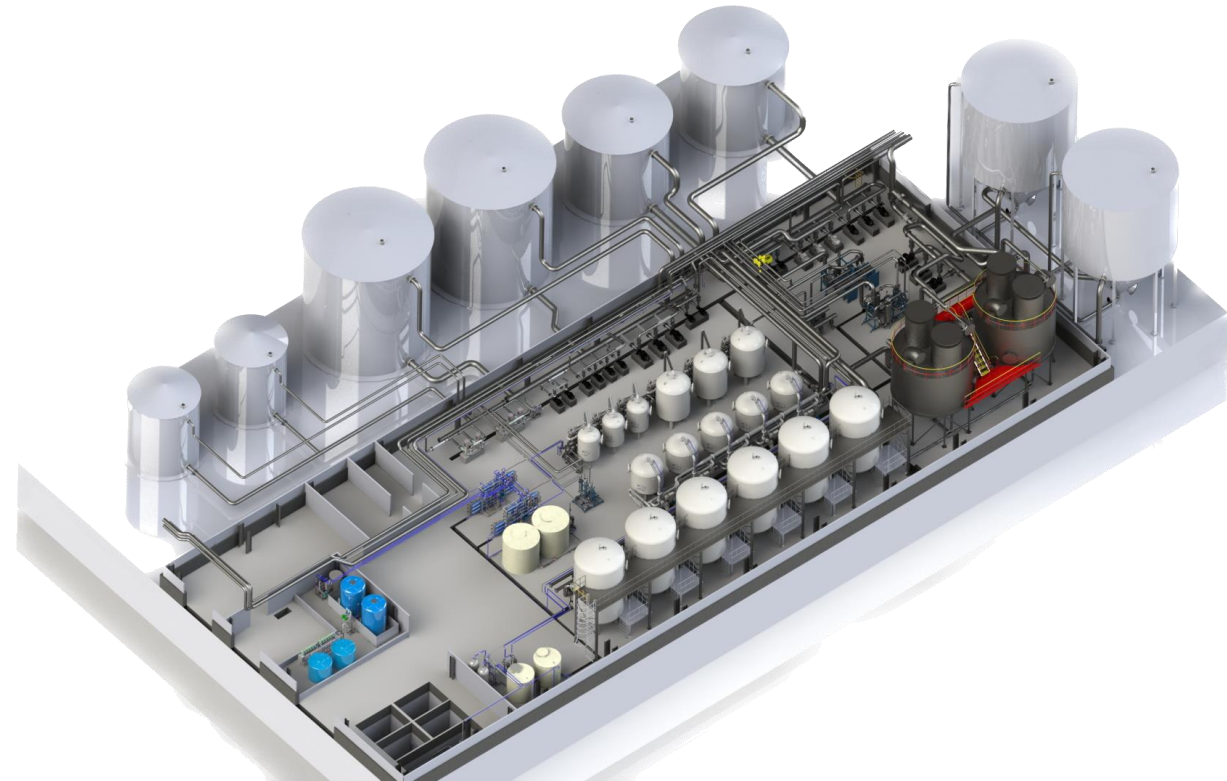



PROVIDED SERVICES **JURBYFLOW**



ULTRAFILTRATION SERIES UF

Designed to remove from natural and wastewater:

- suspended solids;
- colloidal impurities, iron, aluminum, humates;
- turbidity and color of water;
- SDI < 3.



REVERSE OSMOSIS SERIES RO

Designed to remove dissolved impurities and desalinate water with minimal consumption of chemicals.



ELECTRODEIONIZATION SERIES EDI

Designed for deep water desalination reducing electrical conductivity to 0,1 μ S by combining ion exchange and electro dialysis methods.



MEMBRANE DEGASSING SERIES MDE

Designed to remove dissolved gases (oxygen, carbon dioxide, etc.) from water.



PROVIDED SERVICES **JURBYFLOW**



SEA WATER DESALINATION

Reverse osmosis (RO) is the most widely used membrane desalination technology designed to desalinate water with minimal consumption of chemicals.

Membrane processes use reverse osmosis and high pressure to force saltwater through very fine, porous filters that retain the salts, leaving pure water on one side of the membrane and the waste stream on the other side.

The salts and other impurities are retained on the side of the saltwater supply. RO is efficient for low or high concentrations of salts and can thus be used to treat brackish water as well as seawater.





PROVIDED SERVICES **AQUAHARD**



ION EXCHANGE FILTRATION PLANTS SERIES I

Designed for purification of natural and wastewater from dissolved impurities by ion exchange technology.



PUMP STATIONS SERIES P

Designed to supply and increase the pressure of water, effluents, pumping out drains and sludge.



CLEAN-IN-PLACE UNIT SERIES CIP

Designed for ultrafiltration, reverse osmosis or electrodeionization membranes chemical cleaning without disassembly or dismantling in order to restore the original membranes performance.



DOSING UNIT SERIES MX

Designed for dosing chemical solutions such as:

- Coagulants and flocculants;
- Acids and alkalis;
- Antiscalants and biocides;
- Nutritional Supplements for MBR.



FILTRATION UNIT SERIES MF AND AC

MF – to purify by pressure filtration removing suspended solids, iron and manganese.

AC – to purify from toxic substances, dissolved impurities, gases, heavy metals, improve odor, taste and color by sorption filtration.



PROVIDED SERVICES GREENFORT



MEMBRANE BIOREACTOR SERIES MBR

Designed for biological wastewater treatment reducing organic impurities, biogenic substance, suspended solids and colloids to permissible concentration in waterbodies.



OIL TRAP SERIES OS

Designed as thin-layered settling tank for the wastewater, which contains oil products, treatment. It serves to separate suspended sediments from wastewater and to collect pop-up oil products.



FLOTATOR SERIES FL

Designed to reduce high concentrations of suspended solids, oil products and other emulsified liquid substances in wastewater.



SLUDGE TREATMENT PLANT SERIES ST

Technological solution for sludge from wastewater treatment by dehydration and thickening and pretreatment of natural waters.



CLARIFIER SERIES CD

Designed to purify natural and wastewater from suspended solids and coarse impurities at about 6-8 m/h operating deposition rate.

SCOPE OF APPLICATION:

- Pretreatment in industrial water treatment systems;
- Removal of suspended solids and coarse impurities during disposal of waste and wastewater.





JURBY WATERTECH INTERNATIONAL CHEMICAL WATER TREATMENT DIVISION

CHEMICAL WATER TREATMENT DIVISION



CHEMICAL WATER TREATMENT DIVISION INDUSTRIAL WATER SYSTEMS WE TARGET



**OPEN AND CLOSED
COOLING SYSTEMS**



**BOILERS AND HEAT
EXCHANGERS**

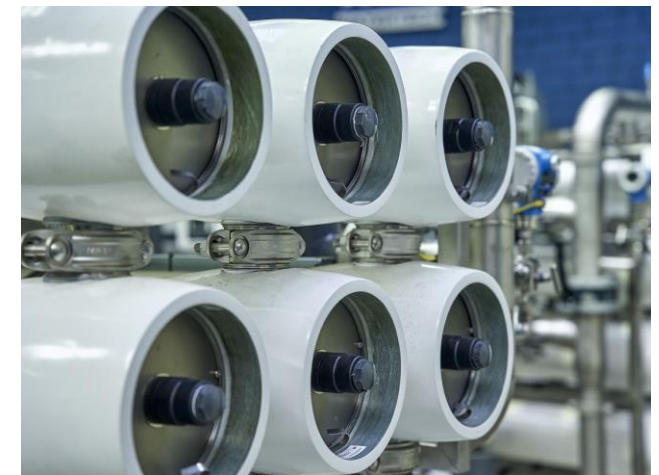

REVERSE OSMOSIS



CHEMICAL WATER TREATMENT DIVISION

THE PROBLEMS WE SOLVE

OUR TEAM WILL HELP YOU TO COPE WITH:

- DETERIORATION OF EQUIPMENT;
- IMPEDED HEAT TRANSFER;
- CARRYOVER;
- MICROBIOLOGICAL CONTAMINATION;
- FREQUENT CLEANING AND SHUTDOWNS.





CHEMICAL WATER TREATMENT DIVISION THE COMPOSITION OF THE DIVISION

CHEMICAL WATER TREATMENT DIVISION CONSISTS OF 3 SUB-UNITS:

- 1. SUPERVISION, SERVICE AND CONSULTING UNIT**
- 2. CHEMICAL PRODUCTS PRODUCTION CENTER**
- 3. RESEARCH AND DEVELOPMENT LABORATORY**

**DIVISION ORGANISATION ENSURES THE
PREMIUM QUALITY OF:**

- Raw materials used in production
- Quality of products JurbySoft® and Roptima®
- Visual control
- Measurement of physical parameters
- Determination of active compounds
- Ensuring verification of requirements
- Completion of quality Protocols and Certificates
- Completion of Safety Data Sheets, etc

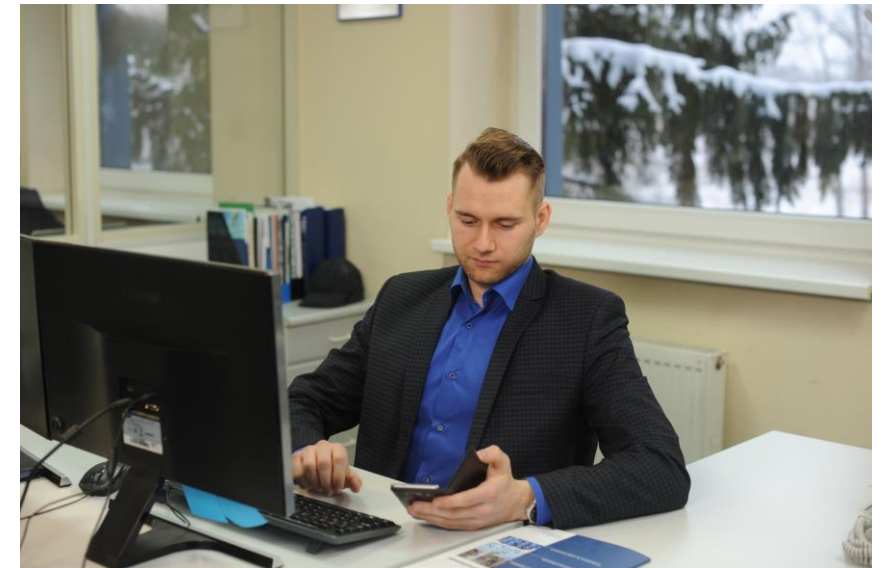



CHEMICAL WATER TREATMENT DIVISION

THE PROBLEMS WE SOLVE

RESEARCH & DEVELOPMENT LABORATORY:

- Specialized in data analysis of scientific information and objects documentation;
- Develops and customizes new products based on client's needs and engineer's submitted problems;
- Selection of suitable and effective chemical treatment programs for different types of processes;
- Investigation of specific problems related to customers' water systems;
- Final process modeling on pilot installations, problem simulation, and monitoring for the evaluation of technology effectiveness, etc.





CHEMICAL WATER TREATMENT DIVISION WILL HELP YOU

DUTIES OF THE UNIT:

- Analysis of industrial water systems parameters and water;
- Survey of plants staff;
- Suitable JurbySoft® chemicals selection;
- Water treatment programme development;
- Dosing and monitoring equipment design;
- Commissioning of dosing and monitoring equipment;
- Commissioning of water treatment programme;
- Supervision of water treatment programme;
- Training of plant staff.





CHEMICAL WATER TREATMENT DIVISION PRODUCTS JurbySoft® and ROptima®

Open/closed cooling systems

- Corrosion and scale inhibitors;
- Biocides;
- Dispersants;

Different types of boilers

- Scale and corrosion inhibitors;
- Oxygen absorbers;
- Condensate inhibitors;
- Cleaners and passivators;

Reverse osmosis

- Various antiscalants;
- Preservation and neutralization chemicals;
- Cleaners;
- Biocides;





CHEMICAL WATER TREATMENT DIVISION AUTOMATIC DOSING AND MONITORING STATIONS

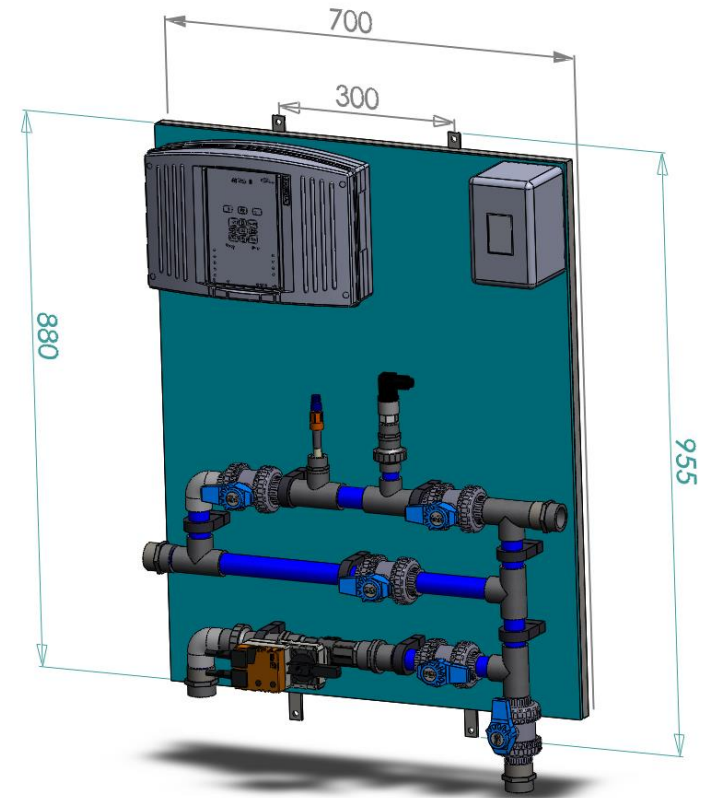
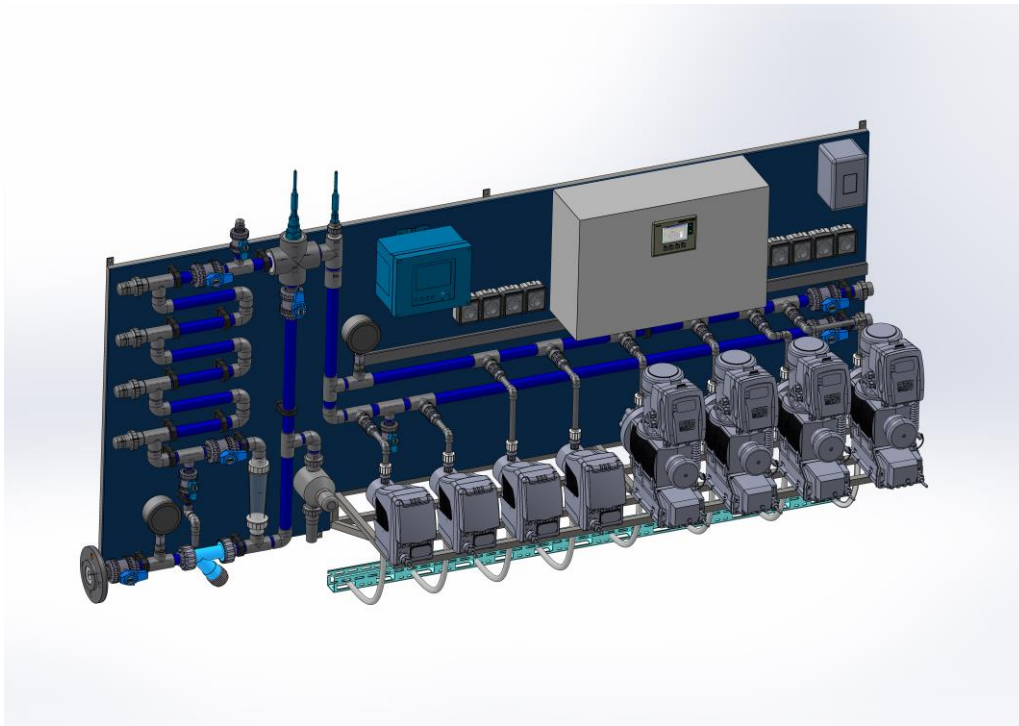



DIVISION OF ENGINEERING

LIST OF COMPLETED PROJECTS

JURBY WATERTech INTERNATIONAL
COMPANY – HAS A GREAT
EXPERIENCE IN THE FIELD OF DESIGN
AND IMPLEMENTATION OF LARGE
OBJECTS FOR THE PREPARATION AND
PURIFICATION OF WATER.



LIETUVOS ENERGIJA: LITHUANIAN POWER PLANT

INTENDED PURPOSE:

Turnkey construction.
Boiler make-up 100 m³/h.
Condensate treatment 100 m³/h.

TECHNOLOGY:

Ultrafiltration unit 4x25 m³/h;
Reverse Osmosis unit -I 4x25 m³/h;
Reverse Osmosis unit -II 4x25 m³/h;
Electrodeionization unit 4x25 m³/h;
Mechanical Filtration unit 20 m³/h;
Softening unit 20 m³/h;
Mechanical Filtration unit 100 m³/h;
MB Ion Exchanger 2x50 m³/h.





SAMRUK ENERGY: EKIBASTUZ SDPS -1

INTENDED PURPOSE:

Boiler make-up, 400 m³/h and heating system feed, 100 m³/h.

TECHNOLOGY:

Ultrafiltration unit 714 m³/h;
Softening unit;
Reverse Osmosis unit -I 490 m³/h;
Reverse Osmosis unit -II 441 m³/h;
Electrodeionization unit 400 m³/h.





PJSC CRYOGENMASH

INTENDED PURPOSE:

Reagent water treatment for the circulating water systems.

TECHNOLOGY:

Chemical dosing units in container version.





BRIDGNORTH ALUMINIUM LTD.

INTENDED PURPOSE:

Process water.

TECHNOLOGY:

Filtration unit 10 m³/h;
Softening unit 10 m³/h;
Reverse Osmosis unit 7,5 m³/h.





OKHTYRKA BREWERY JSC

INTENDED PURPOSE:

Expansion of the existing WTP;
technology needs.

TECHNOLOGY:

Filtration unit 30 m³/h;
Reverse Osmosis unit 28 m³/h;
CIP system;
UV- disinfection plant 20 m³/h.





KRASYLIVSKE BREWERY

INTENDED PURPOSE:

Process water.

TECHNOLOGY:

Deironing F 110 m³/h;
sorption plant 110 m³/h;
softening unit 110 m³/h;
Reverse Osmosis unit 5x15 m³/h.





MIRONOVSKIJ HLEBOPRODUCT

INTENDED PURPOSE:

WTP, 685 m³/h (first stage).

TECHNOLOGY:

Clarification A-Stream 250x4;

Filtration, 685 m³/h.





SAKHALIN – 2 (WORLEY PARSONS) OIL AND GAS PROJECT

INTENDED PURPOSE:

Drinking and domestic water treatment.

TECHNOLOGY:

Filtration unit 20 m³/h
(Container type).





ACHEMA, LEADING PRODUCER OF NITROGEN FERTILIZERS AND CHEMICAL PRODUCTS IN LITHUANIA

INTENDED PURPOSE:

Boiler make-up.

TECHNOLOGY:

Clarification unit 750 m³/h;
Ion Exchange unit 750 m³/h;
Mixed Bed unit 590 m³/h.





THANK YOU!

JURBY WATERTech INTERNATIONAL

www.jurby.com