

HIGH SPEED CLARIFIER - A-STREAM

JURBY A-STREAM CD®

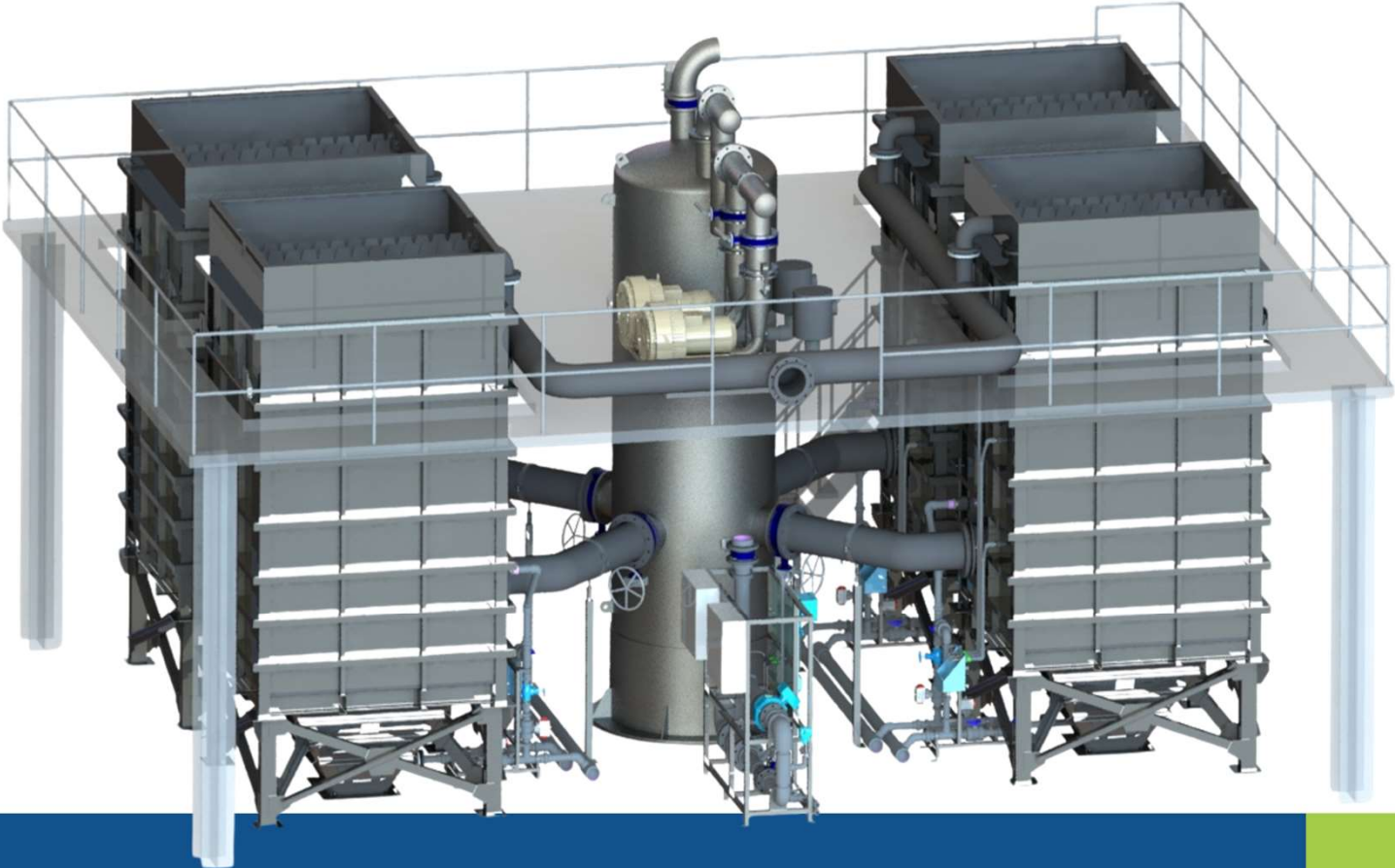

JURBY

A-STREAM CLARIFIER WITH PULSATION PRINCIPLE



A-STREAM CLARIFIER is a high-speed lamellar clarifier based on pulsation mode.

A-STREAM is used in **MUNICIPAL** and **INDUSTRIAL** water and wastewater treatment:

- Water Pre-treatment
- Backwash Water Treatment
- Primary and Secondary Settling

Clarification removes suspended solids (TSS) from raw water and partially removes organic matter that can be coagulated.



JURBY

GENERAL FLOW-SHEETS

A-STREAM can be used as a pretreatment stage for:



Potable water purposes



Food and beverage industries



Desalination and process purposes

- Metallurgical industry;
- Power industry;
- Oil refining and Petrochemical industry;
- Other industries.

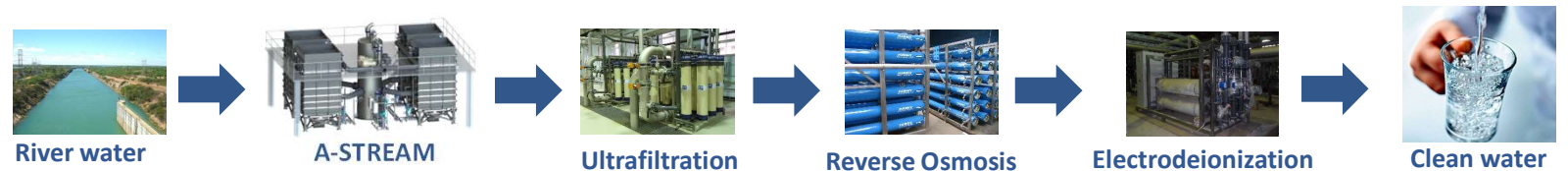

Industrial wastewater treatment

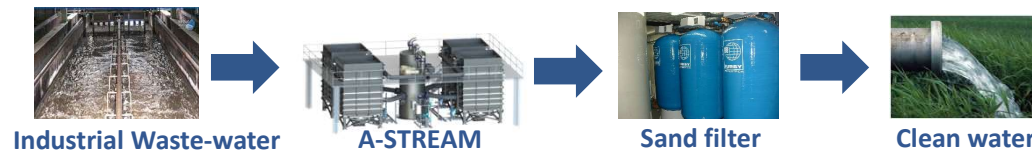

A-STREAM ADVANTAGES



HIGH PERFORMANCE

A-STREAM is a high-speed clarifier, which capacity is 2 times higher than standard clarifiers despite a smaller footprint

CUSTOMER-SPECIFIC CAPACITY

Can be easily designed to produce from 25 to 100 m³/h of water or more depending on customer needs

QUICK AND EASY INSTALLATION

A-STREAM is factory assembled unit, requires low installation costs

EASY DELIVERING

Equipment can be delivered with standard freight truck

COMPACT SIZE

A-STREAM unit is about 6 meters high, which does not require great space compared to classic clarifiers

AUTOMATICAL OPERATION

The installation is automated and does not require the presence of personnel

EASY CLEANING OR REPLACEMENT

Each lamella shelf is a separate component that can be easily extracted from the clarifier housing, for example, for the purpose of cleaning procedures.

NO CORROSION

A-STREAM clarifier is made of polypropylene shell enclosed by the steel frame.



JURBY

OPERATION PRINCIPLE

A-STREAM is a high-speed clarifier operating at an ascent rate of 6-8 m/h.

Operation is based on water pulsations, generated by the pulsator. Unique pulse profile, created by the external air pressure, enables effective sedimentation of suspended particles.

Raw water is supplied to the pulsator from which it is rapidly pushed out to the clarifiers using air blower. As a result, the sludge receives an impulse, causing its particles to coalesce and settle. Water pulsation is repeated every 40-50 seconds.

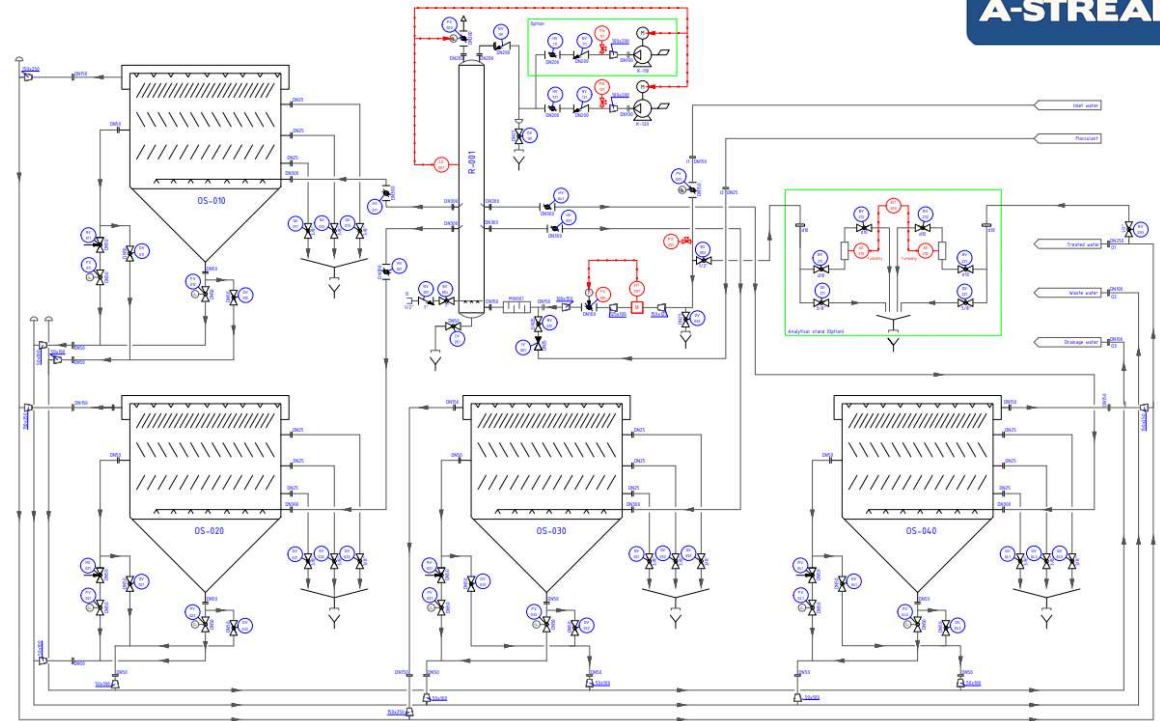

JURBY

CONSTRUCTION PRINCIPLE

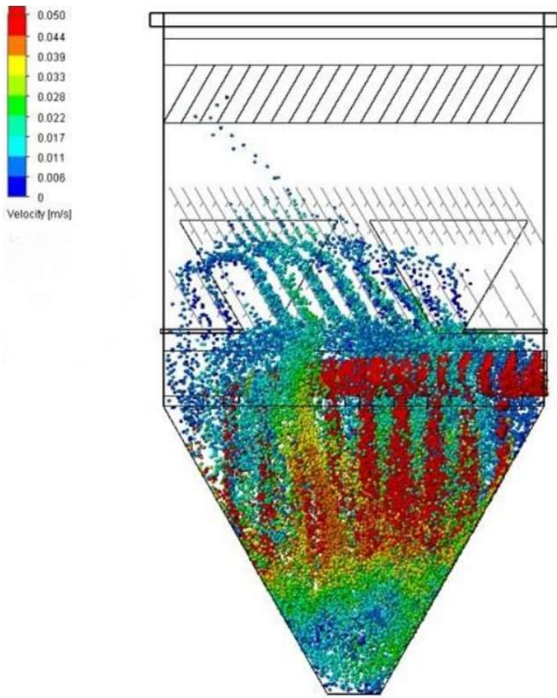

Clarifiers are made of polypropylene shell enclosed by the steel frame.

Clarifier shell contains case of three lamella shelves, water inlet/outlet and sludge outlet distributors.

Block of lamella shelves is an individual component, which can be easily taken out from the clarifier for cleaning.

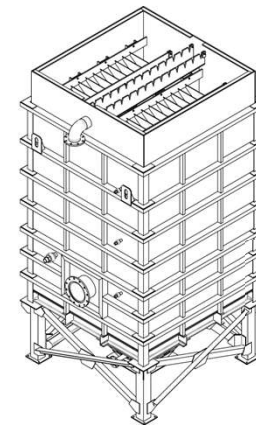

JURBY

SCOPE OF DELIVERY

CLARIFIER UNIT COSISTS OF:

- Clarification Modules (from 1 to 4);
- Pulsation Modul;
- Air Blowing Unit;
- Source Water Inlet Unit;
- Valves and Control Measuring Instruments for Automatic Control;
- Automatic Control Cabinet;
- Sludge Discharge Unit;
- General Piping Distribution.

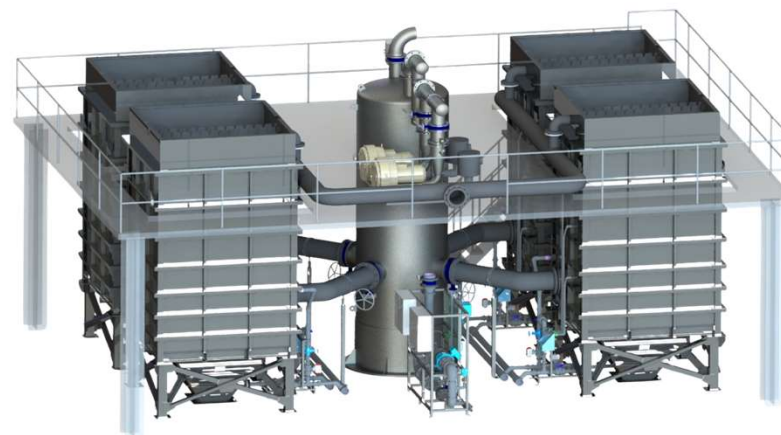

A-STREAM can be supplied by **ADDITIONAL EQUIPMENT:**

- Water Turbidity Analysis Instruments;
- Reserve Equipment (Air Blower);
- Flocculator (for primary water treatment with chemical reagents);
- Dosing and Chemical Preparation Units.



JURBY

ADVANTAGES OF A-STREAM COMPARED TO CLASSIC SLUDGE BLANKET CLARIFIERS

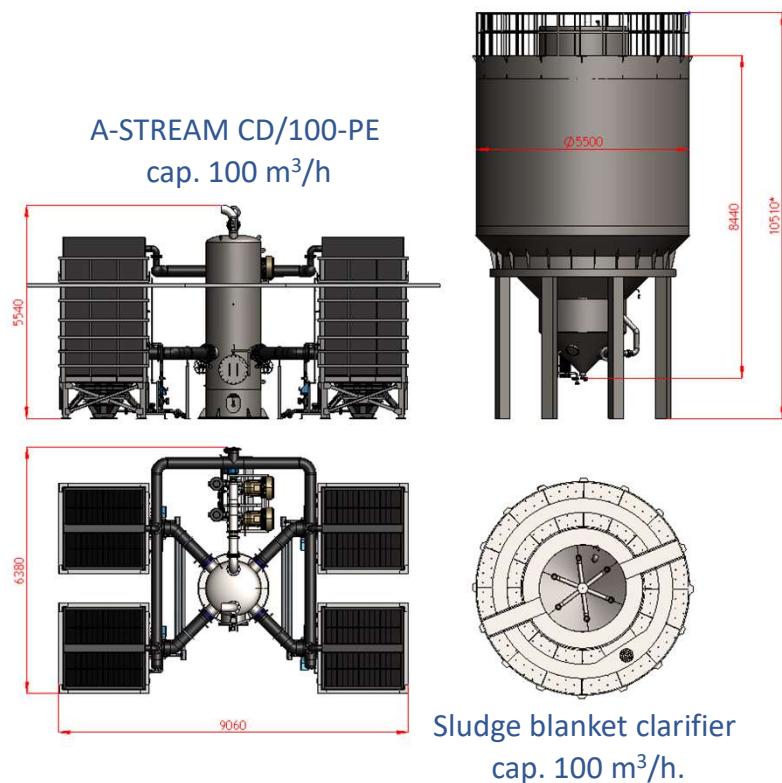

Parameters	-	A-STREAM	Classic sludge blanket clarifier
Req. height of the building	m	5.5	10.5
Drains	%	3	1
Outlet SS	mg/l	≤ 5	≤ 5
Weight of the equipment	t	17.5	13.5
Unit mass	t	88	170



ADVANTAGES OF A-STREAM COMPARED TO CLASSICAL CLARIFIERS

	A-STREAM	Classic sludge blanket clarifier	Static settling tanks with horizontal flow	Static settling tanks with vertical flow
FLOCCULATION	integrated	integrated	prior or integrated	prior or integrated
APPARENT SETTLING VELOCITY AT SURFACE (m/h)	6-10	3-5	0.5-2	0.5-2
CONCENTRATION OF EXTRACTED SLUDGE (g/l)	2-10	2-10	1-5	1-5

- Handling high raw solids (0 to 2000+ NTU);
- Clarified turbidity of <1-2 NTU;
- Minimal energy consumption;
- Very low or zero polymer dosage;
- Sludge handling benefits:
 - high underflow sludge concentrations,
 - low cost for sludge withdrawal.



CONFIGURATION OPTIONS. NOMINAL CAPACITIES, m³/h.

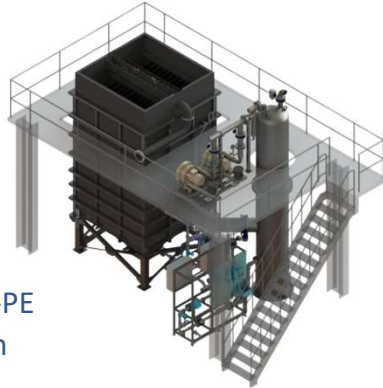

A-STREAM CD/25-PE
cap. 25-30 m³/h

A-STREAM CD/75-PE
cap. 75-85 m³/h

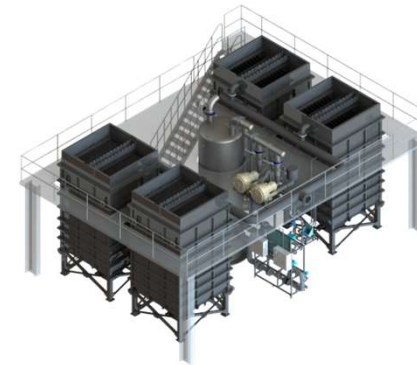
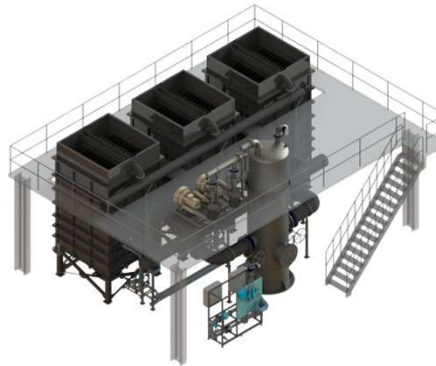

A-STREAM CD/100-PE
cap. 100-120 m³/h

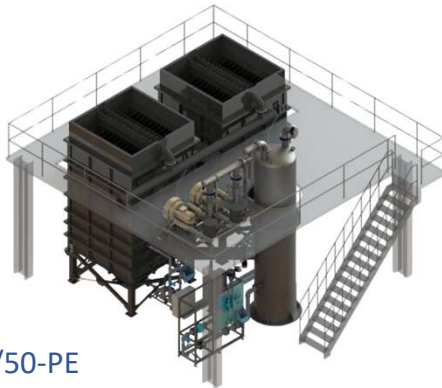

A-STREAM CD/50-PE
cap. 50-60 m³/h

* other installation options can be provided
at the customer's request

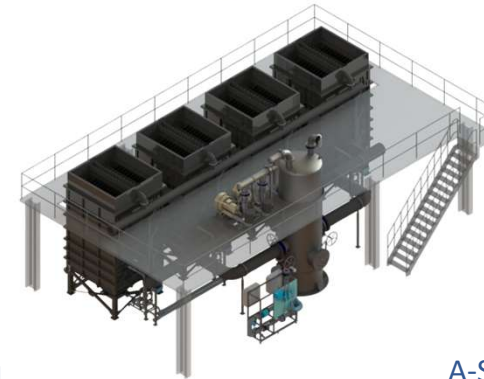

A-STREAM CD/100-PE line
cap. 100-120 m³/h



JURBY

ADDITIONAL EQUIPMENT

FLOCCULANT PREPARING FACILITY FOR PRETREATMENT OF SOURCE WATER

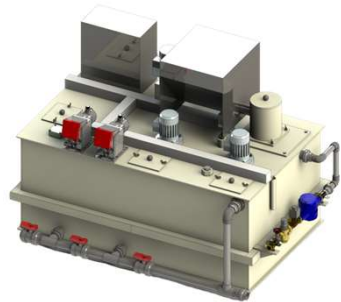

Flocculant production and dosing unit 500 l/h



2 row Flocculator with dosing tanks

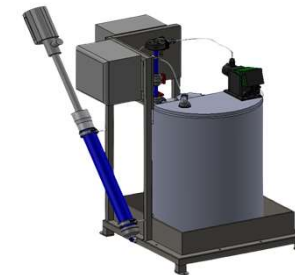

Dosing Unit

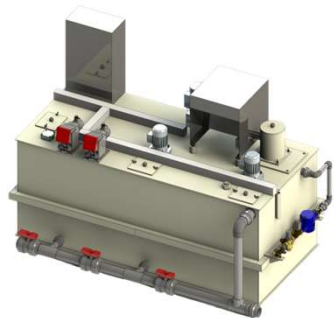

Flocculant production and dosing unit 1000 l/h



3 row Flocculator with dosing tanks

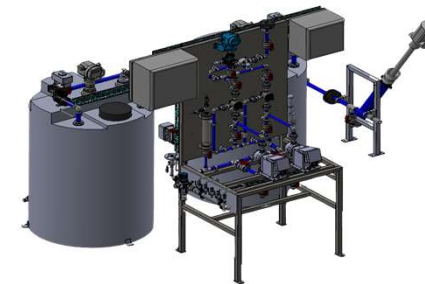

Dosing Unit



JURBY